

Air Quality Monitoring (AQM) Sensors

1. Description

SemeaTech’s Air Quality Monitoring (AQM) sensors are designed based on 7-series electrochemical (EC) gas sensor platform by converting the dummy pin (the 4th pin) into a functional electrode. These sensors are also named 4-electrode gas sensors ideally used for AQM or the applications that require very low parts per billion (ppb) detection levels.

For a typical EC sensor, the “baseline” is defined as the output from the sensing electrode when the target gas is not detected. It is a function of certain parameters, mainly ambient temperature. The variation of sensor baseline affects the accuracy of the sensor output. The 4th pin, Auxiliary electrode, on a 4-electrode gas sensor is a low sensitivity sensing electrode that is used to correct the baseline drift on the sensing electrode. Combining the outputs from both sensing and auxiliary electrodes significantly improves the performance of the traditional gas sensors in accuracy, resolutions, baseline stability, repeatability, and environmental independence.

2. Dimensions

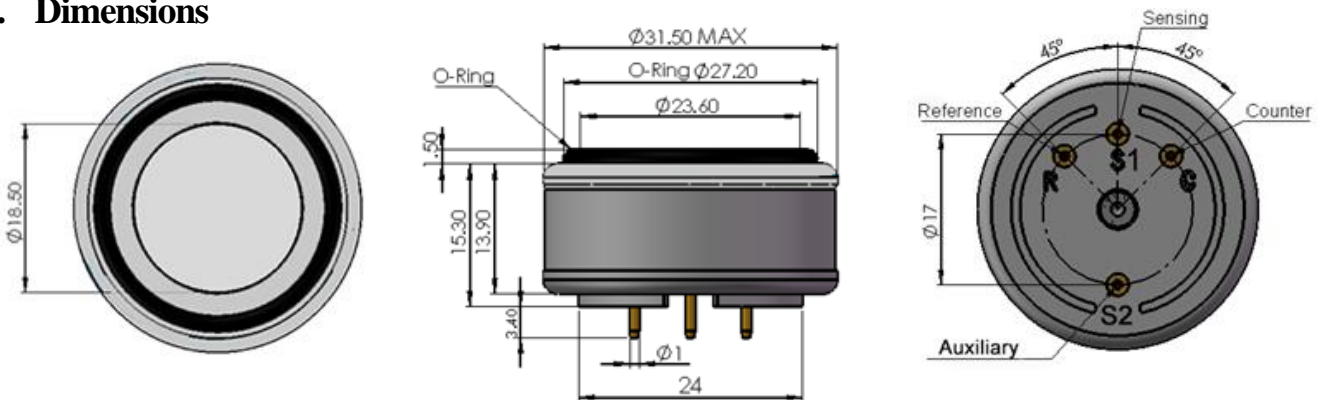

3. Recommended Schematics

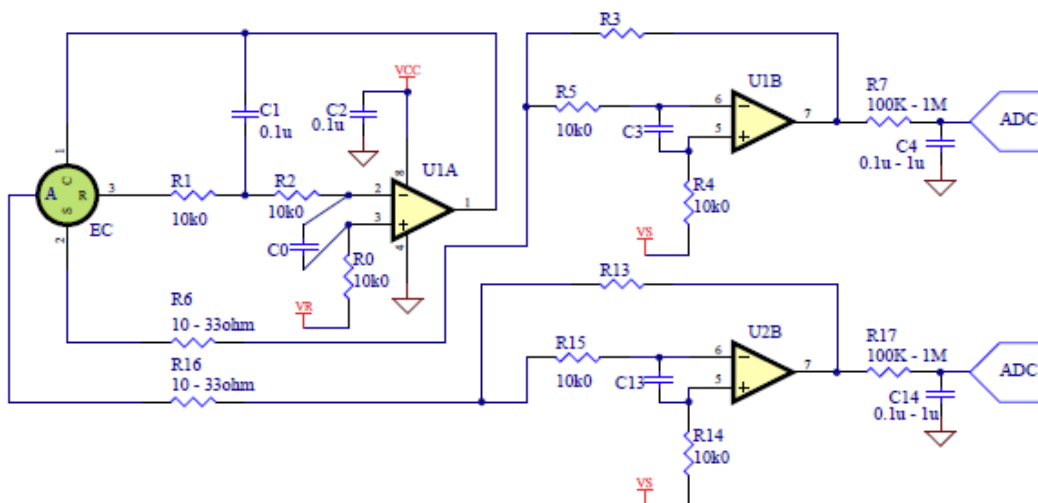

Notes: 1) In this reference schematic, VS and VR are reference voltages and should be short for the sensors with no bias voltage, such NO₂, SO₂, O₃ and CO sensor. It is recommended to set VS=VR=1.5V. 2) For the sensors with bias voltage, such as NO(bias +300mV), it is recommended to set VS-VR=300mV

4. Instruction for Use

4.1 Calibration of Sensing and Auxiliary Electrodes

Assume	Calibration gas concentration:	C_0	
	Sensing baseline output current:	I_{10}	Auxiliary baseline output current: I_{20}
	Sensing output current at C_0 :	I_1	Auxiliary output current at C_0 : I_2
	Sensitivity of Sensing at C_0 :	S_1	Sensitivity of Auxiliary at C_0 : S_2

Then

$$I_1 = S_1 \times C_0 + I_{10} \dots\dots\dots (1)$$

$$I_2 = S_2 \times C_0 + I_{20} \dots\dots\dots (2)$$

$$S_1 = (I_1 - I_{10}) / C_0 \dots\dots\dots (3)$$

$$S_2 = (I_2 - I_{20}) / C_0 \dots\dots\dots (4)$$

4.2 Output Current from Sensing and Auxiliary for Unknown Target Gas Concentration C

Assume	Sensing output current at C:	I_{1C}	Auxiliary output current at C: I_{2C}
--------	------------------------------	----------	---

Then

$$I_{1C} = S_1 \times C + I_{10} \dots\dots\dots (5)$$

$$I_{2C} = S_2 \times C + I_{20} \dots\dots\dots (6)$$

4.3 Calculation of Unknown Target Gas Concentration C

$$I_{1C} - I_{2C} = (S_1 - S_2) \times C + (I_{10} - I_{20}) \dots\dots\dots (7)$$

$$C = ((I_{1C} - I_{2C}) - (I_{10} - I_{20})) / (S_1 - S_2) \dots\dots\dots (8)$$

Sensing and Auxiliary electrodes are made from the same materials and processes, and the working areas of both electrodes are equal, so their baseline outputs are very close to each other as designed. Thus $I_{10} - I_{20} = 0$, and Equation (8) can be simplified to

$$C = (I_{1C} - I_{2C}) / (S_1 - S_2) \dots\dots\dots (9)$$

This is how unknown target gas concentration C is calculated in general.

For better accuracy with the consideration of ambient temperature influences, Equation (8) needs to be changed to

$$C = ((I_{1C} - I_{2C}) - \Delta(T)) / (S_1 - S_2) \dots\dots\dots (10)$$

Here $\Delta(T) = I_{10} - I_{20}$ that can be obtained from the temperature curves individually for each electrode.

However, Temperature Data in the sensor datasheet have taken the consideration of it for user's convenience.